

00	ORGANE DE BASE MOTEUR
	ENGINE BASIC COMPONENT
	GRUNDORGAN MOTOR

42	ORGANE ALIMENT. COMBUSTIBLE
	GAS-OIL SUPPLY COMPONENT
	ORGAN GAS OL VERSORGUNG

206	MOTEURS M 42 SB-L 63 S «GROUPE»
	ENGINES M 42 SB-L 63 S «GROUPE» CAB
	MOTOREN M 42 SB-L 63 S « GROUPE »

00	42	206	n° édition catalogue	n° de planche
1	2	3	4	5

Réservoirs <i>Fuel tank</i> <i>Kraftstofftank</i>	00	01
Filtre et tuyauteries de combustible <i>Filter and fuel lines</i> <i>Filter und leitungen</i>	00	02

**VALIDITE DU
TYPE D'ORGANE**

**COMPONENT
APPLICABILITY**

**GÜLTIGKEIT
DES
ORGANTYPES**

MOTEUR	M 42 SB : 2280
ENGINE	L 63 S : 2899
MOTOR	

1	ORGANE DE BASE	BASIC COMPONENT	GRUND-ORGAN
2	ORGANE	COMPONENT	ORGAN
3	TYPE D'ORGANE	COMPONENT TYPE	ORGANTYP
4	N° ÉDITION	CATAL. EDITION NUMBER	NUMMER DER AUSGABE
5	N° PLANCHE	PLATE NUMBER	BILD Nr.
6	REPÈRE	MARKING	KENNZIFFER

7	N° PIÈCE	PART N°	TEIL Nr.
8	DÉSIGNATION	DESIGNATION	BESCHRIFTUNG
9	QUANTITÉ	QUANTITY	MENGE
10	CODE OBSERVATIONS	CODE OF OBSERV.	ANMERKUNGEN KODE
11	DÉTAILS OBSERVATIONS	DETAILS OF OBSERV.	ANMERKUNGEN BEDEUT.

Reference
Kennzahl **655.760**
EDITION
AUSGABE **15/12/72**

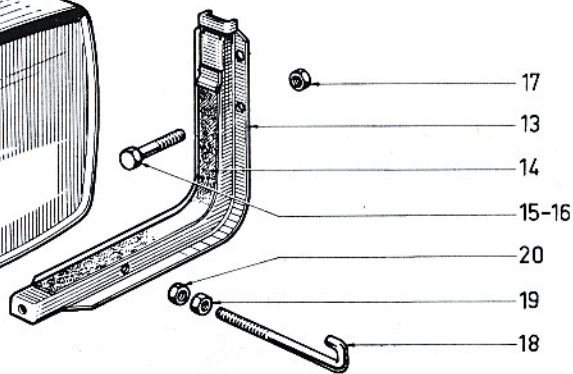
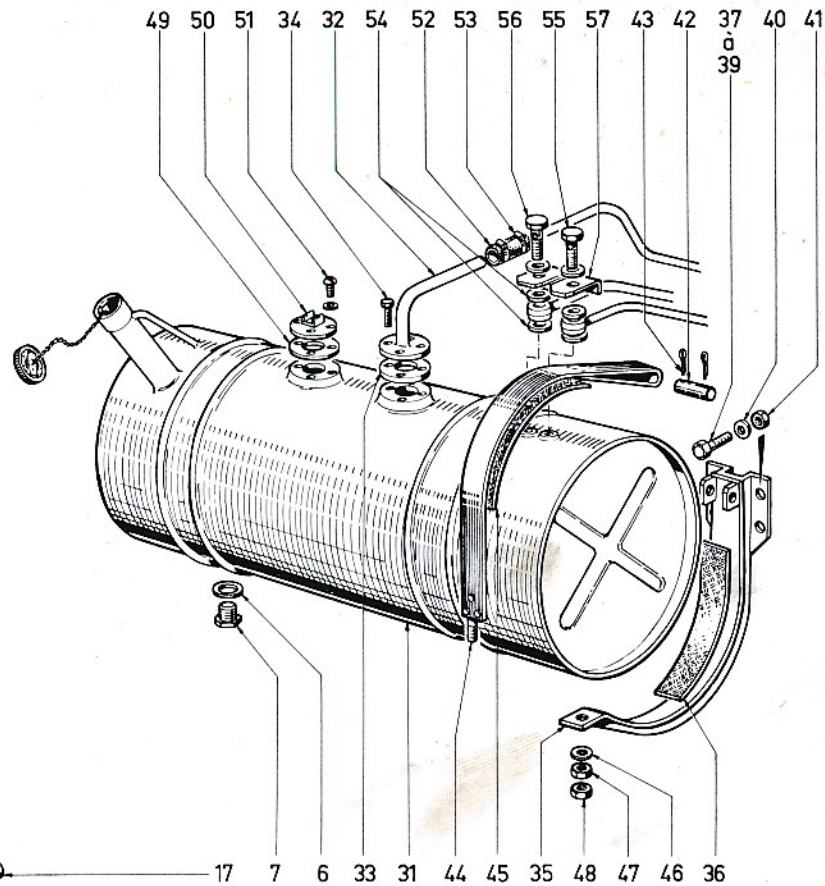
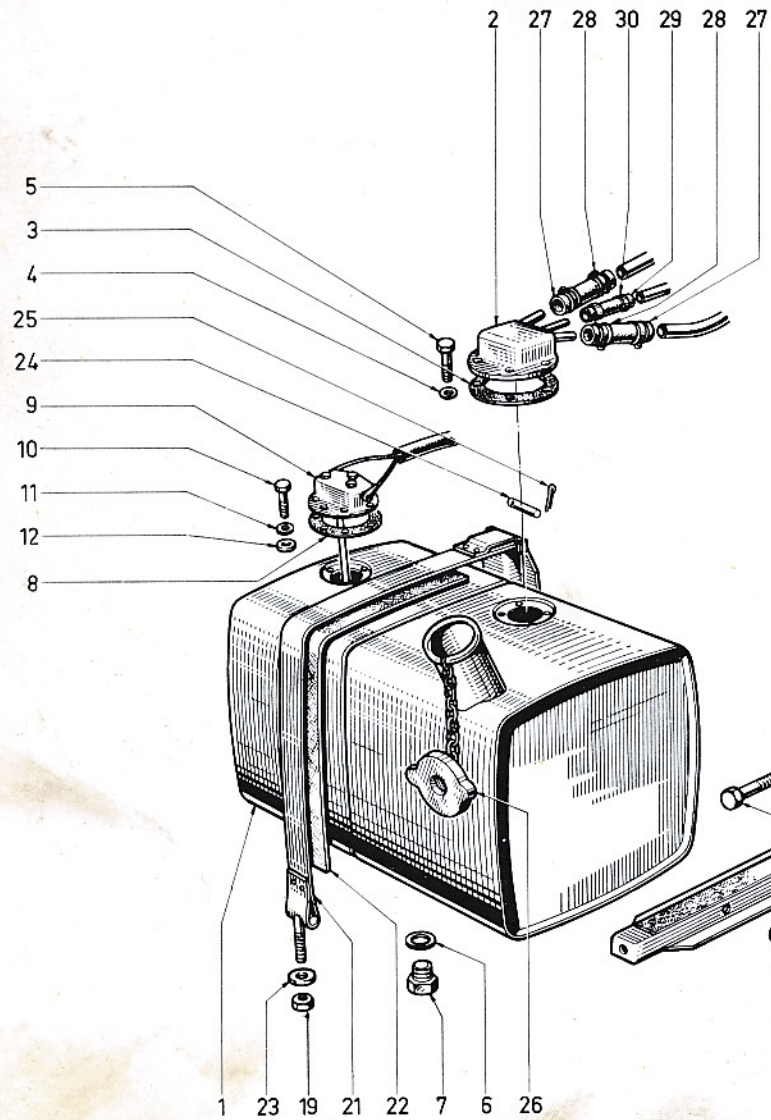

00	42	206	00	01
1	2	3	4	5

6	7	8	9	10
1	61666290	RESERVOIR 300L	1	
2	61666516	PLONGEUR	1	
3	61213339	JOINT	1	
4	61101597	RONDELLE	4	
5	61404707	VIS	4	
6	61238489	JOINT	1	
7	61216526	BOUCHON	1	
8	61574858	JOINT	1	
9	61670181	JAUGE ASS.	1	
10	61234169	VIS	6	
11	61234170	CUVETTE	6	
12	61234171	RONDELLE	6	
13	61668504	SUPPORT ASS	2	
14	61233351	GARNITURE	2	
15	61803190	VIS	6	
16	61803191	VIS	2	
17	61801355	ECROU	8	
18	61235595	BUTEE	2	
19	61801012	ECROU	4	
20	61801065	CONTRE ECROU	2	
21	61663543	SANGLE ASS	2	
22	61232171	GARNITURE	2	
23	61815225	RONDELLE	2	
24	61232172	AXE	2	
25	61819922	GOUPILLE	4	

10	11

6	7	8	9	10
26	61652835	BOUCHON	1	
27	61077480	DURITE	2	
28	61225203	COLLIER	4	
29	61238708	DURITE	1	
30	61096566	COLLIER	2	
31	61667912	RESERVOIR 200L	1	
32	61274464	PLONGEUR ASS	1	
33	61110003	JOINT	1	
34	61400121	VIS	4	
35	61659758	SUPPORT	2	
36	61227829	GARNITURE	2	
37	61803190	VIS	2	
38	61803191	VIS	4	
39	61803185	VIS	2	
40	61815226	RONDELLE	2	
41	61801355	ECROU	6	
42	61211618	AXE	2	
43	61619931	GOUPILLE	4	
44	61659760	SANGLE ASS	2	
45	61227830	GARNITURE	2	
46	61815005	RONDELLE	2	
47	61400020	ECROU	2	
48	61414890	ECROU	2	
49	61574984	JOINT	1	
50	61670730	JAUGE	1	

10	11

00	42	206	00	01
1	2	3	4	5

DÉSIGNATION PLANCHE : SE RÉFÉRER AUX PAGES "SOMMAIRE"

PLATE DESIGNATION : REFER TO FLYLEAF

BILDBESCHRIFTUNG : SIEHE VORSATZBLÄTTER



6	7	8	9	10
51	61404707	VIS	3	
52	61077480	DURITE	1	
53	61225203	COLLIER	2	
54	61238489	JOINT	4	
55	61667010	PLONGEUR ASS	1	
56	61216386	VIS CREUSE	1	
57	61216387	FREIN	2	

6	7	8	9	10

10	11

10	11

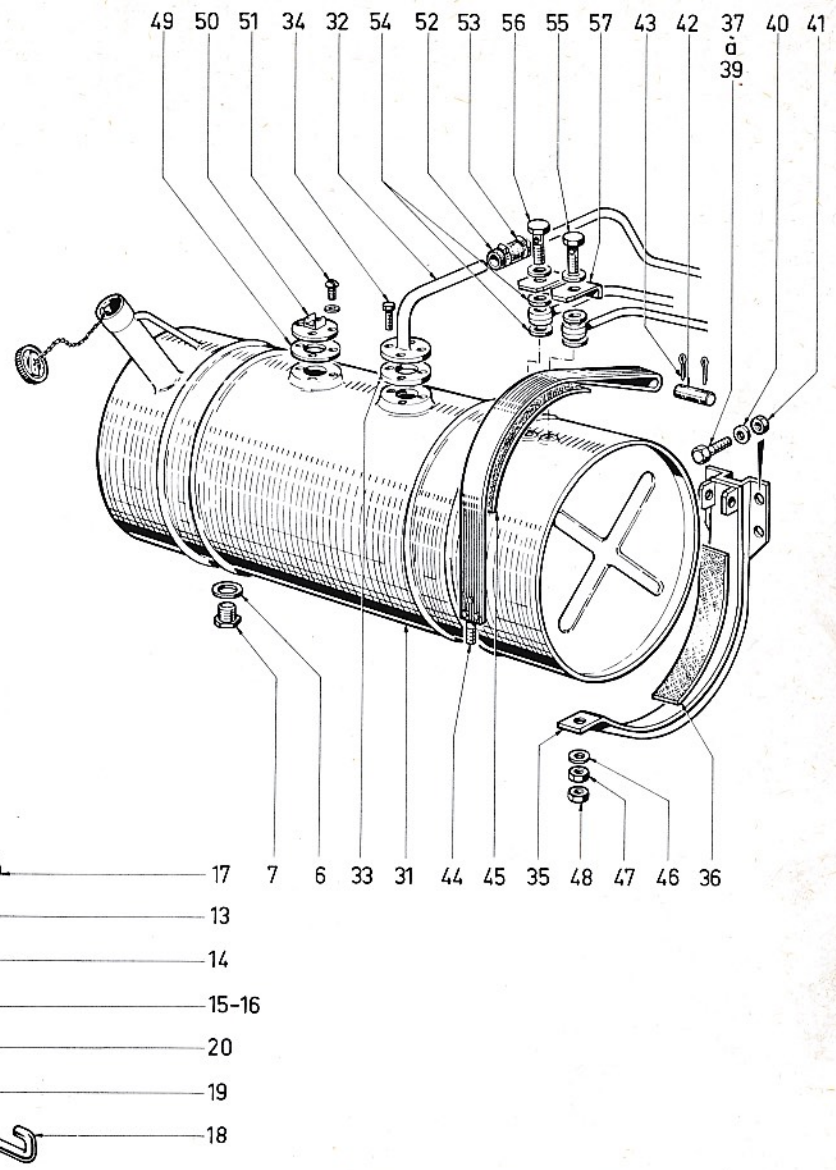
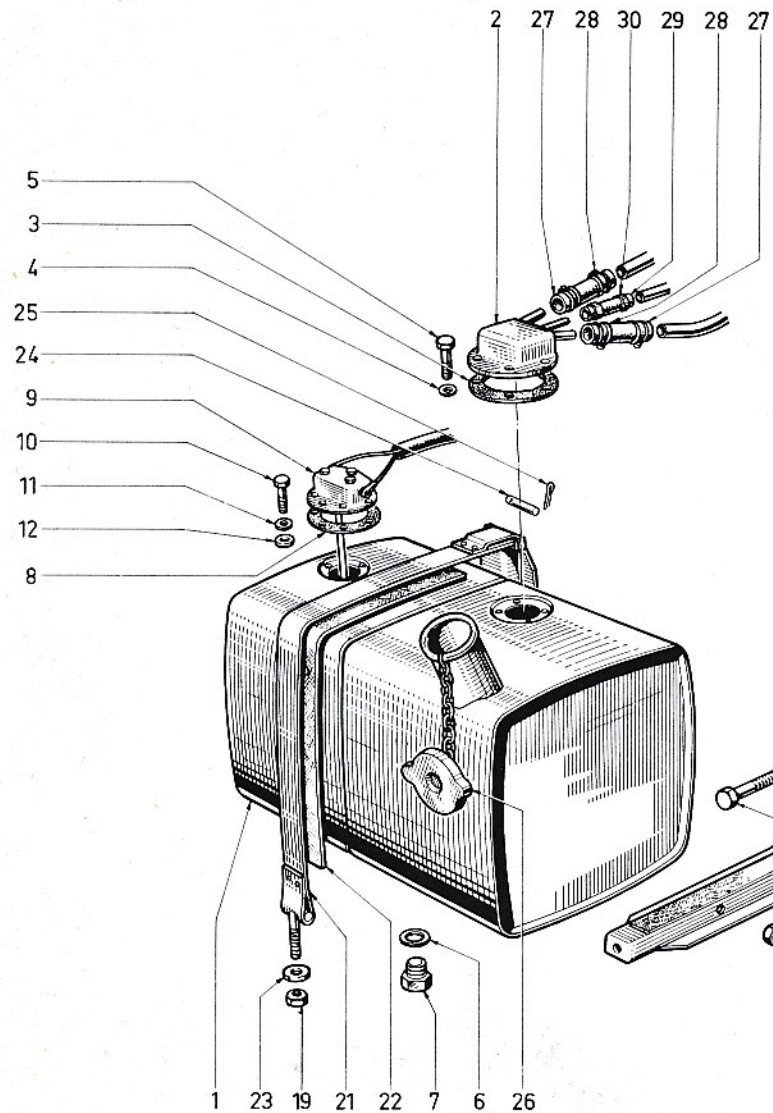

00	42	206	00	01
1	2	3	4	5

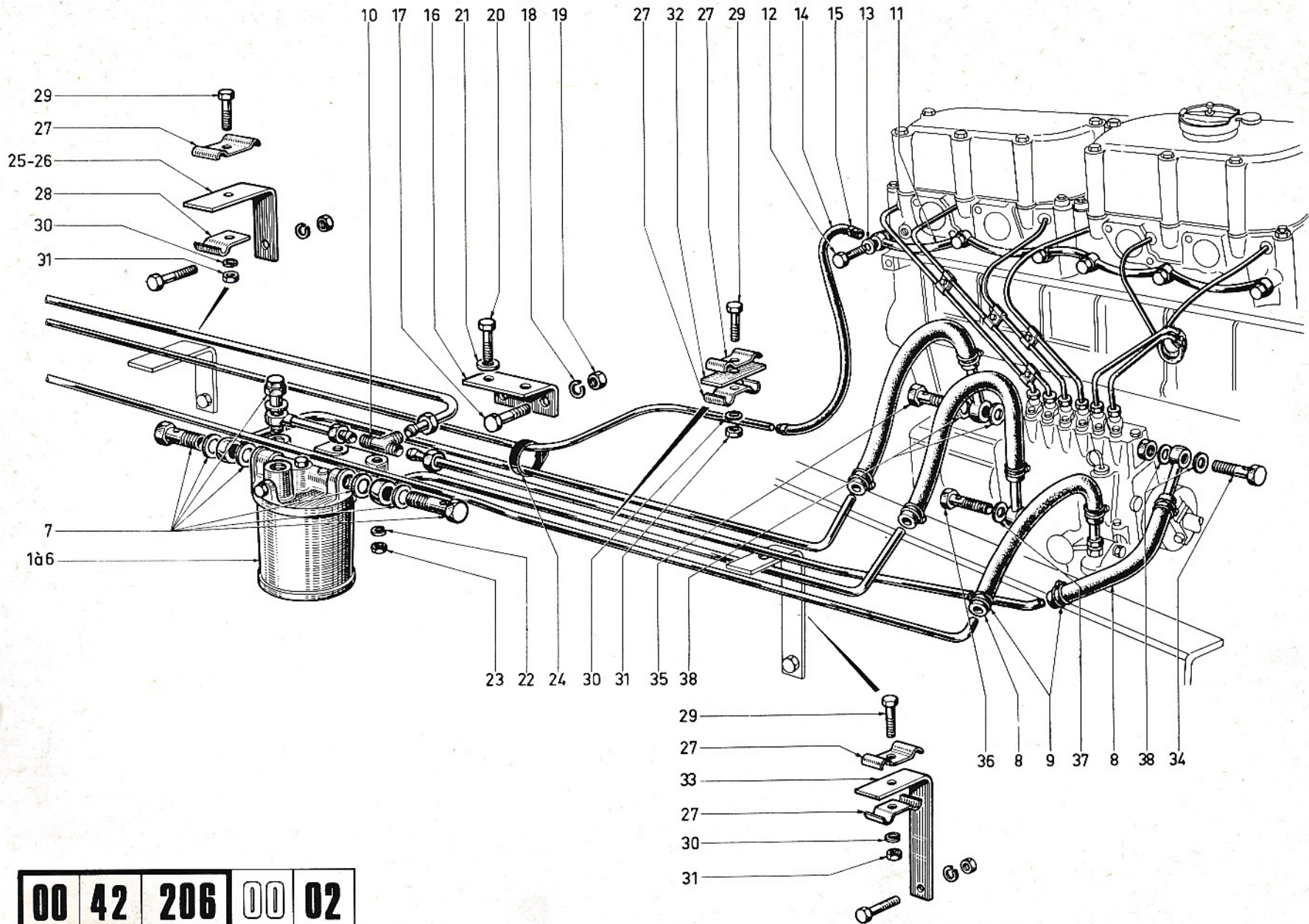

00	42	206	00	02
1	2	3	4	5

6	7	8	9	10
1	61298339	FILTRE FS80M2D	1	
2	61251961	CARTOUCHE FILT	1	
3	61234146	CORPS	1	
4	61662753	FILTRE S80D	1	
5	61662756	CARTOUCHE FILT	1	
6	61662755	CORPS	1	
7	61254777	SACHET REPARAT	1	
8	61250643	DURITE	4	
9	61225203	COLLIER	8	
10	61250527	RACCORD TE	1	
11	61666611	TUYAUTERIE REC	1	
12	61224938	VIS CREUSE	6	
13	61815025	JOINT	12	
14	61226563	DURITE	1	
15	61096566	COLLIER	2	
16	61221111	SUPPORT	1	
17	61803107	VIS	2	
18	61815224	RONDELLE	2	
19	61801011	ECROU	2	
20	61803150	VIS	2	
21	61815005	RONDELLE	2	
22	61815225	RONDELLE	2	
23	61801012	ECROU	2	
24	61254954	COLLIER	1	
25	61237495	PATTE	1	

6	7	8	9	10
26	61237494	PATTE	1	
27	61830727	COLLIER	6	
28	61830705	COLLIER	3	
29	61803090	VIS	6	
30	61815303	RONDELLE	6	
31	61801010	ECROU	6	
32	61237495	PATTE	1	
33	61237493	PATTE	1	
34	61237756	SCUPAPE	1	
35	61251960	VIS CREUSE	2	
36	61105216	VIS CREUSE	1	
37	61105249	JOINT	4	
38	61251954	JOINT	6	
998	61902712	TUBE 8X10		213
999	61902710	TUBE 4X6		213

10	11
213	Tube (vendu au mètre) Tube (sold by the metre) Rohr (pro Meter)

10	11